

Fisher & Paykel

Parts Manual

DRYERS

MODEL

DE06-US1 ELECTRIC

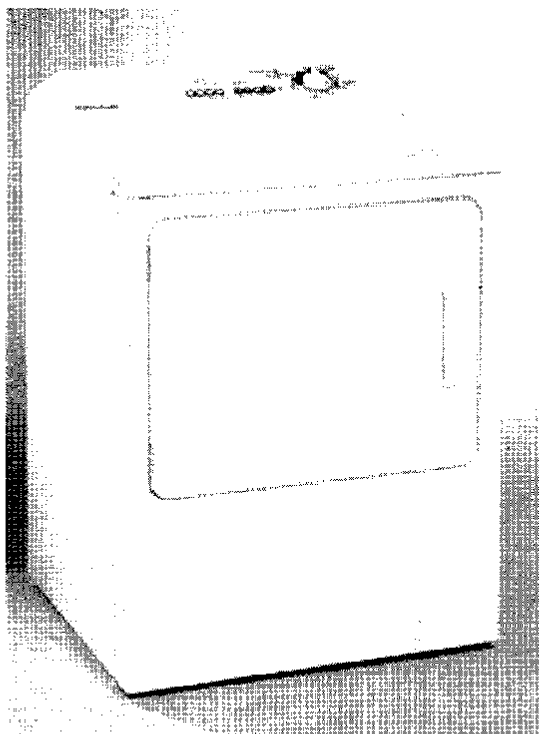

Fisher & Paykel Appliances Ltd.

27 Hubble, Irvine, CA 92618

Tel: (949) 790 8900 (888) 936 7872

Fax: (949) 790 8913

FB200513

11/03

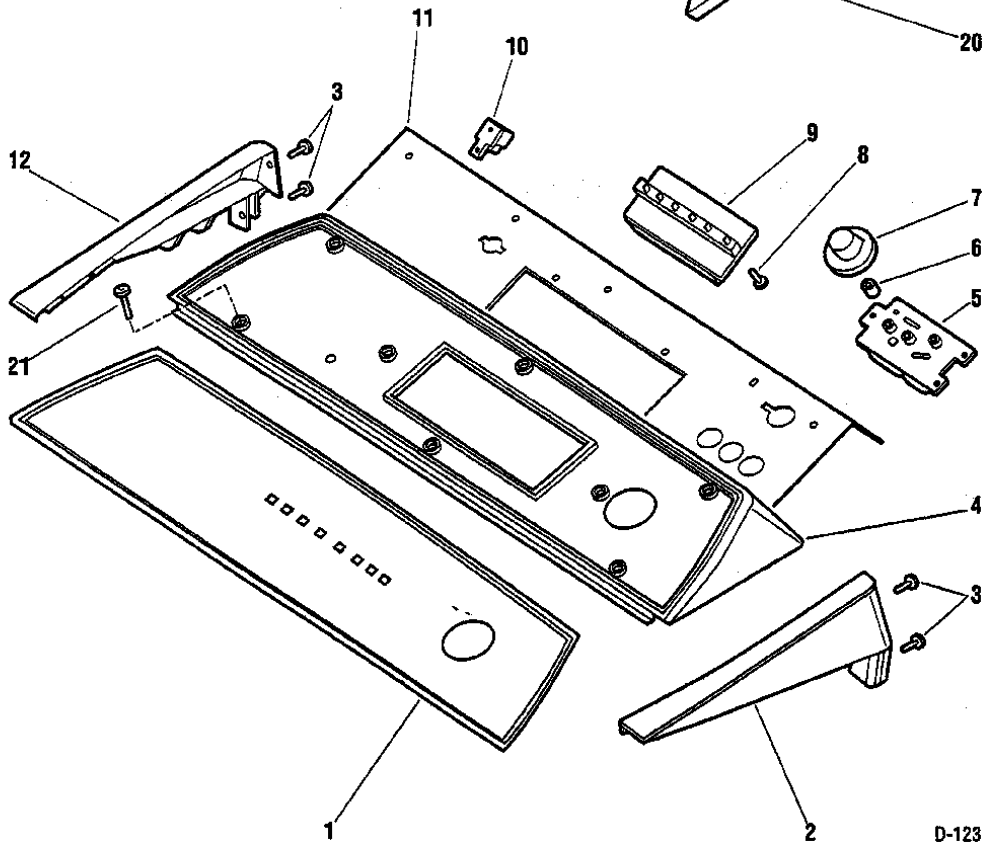
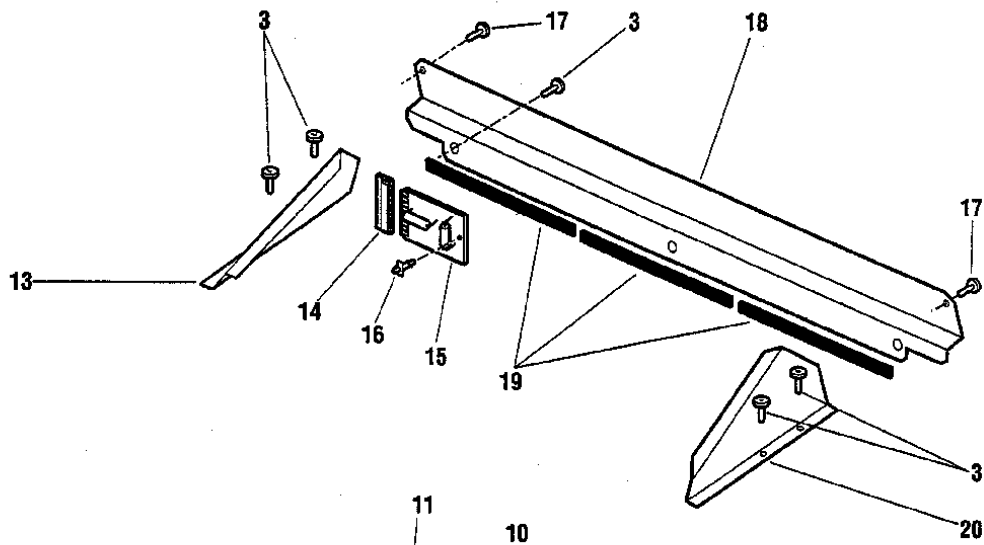

D-123

MODELS

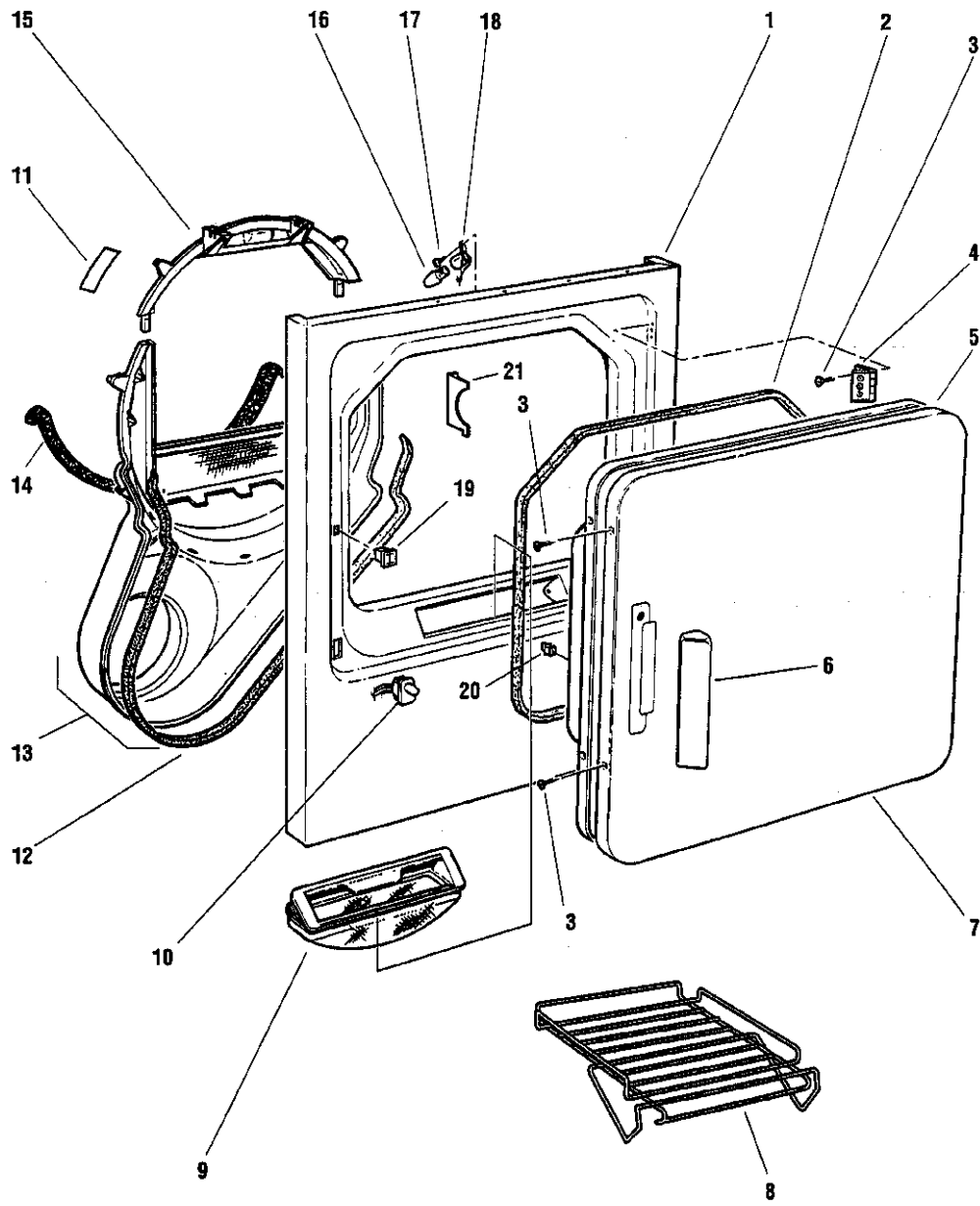

D-180

Copyright © 2000 Camco

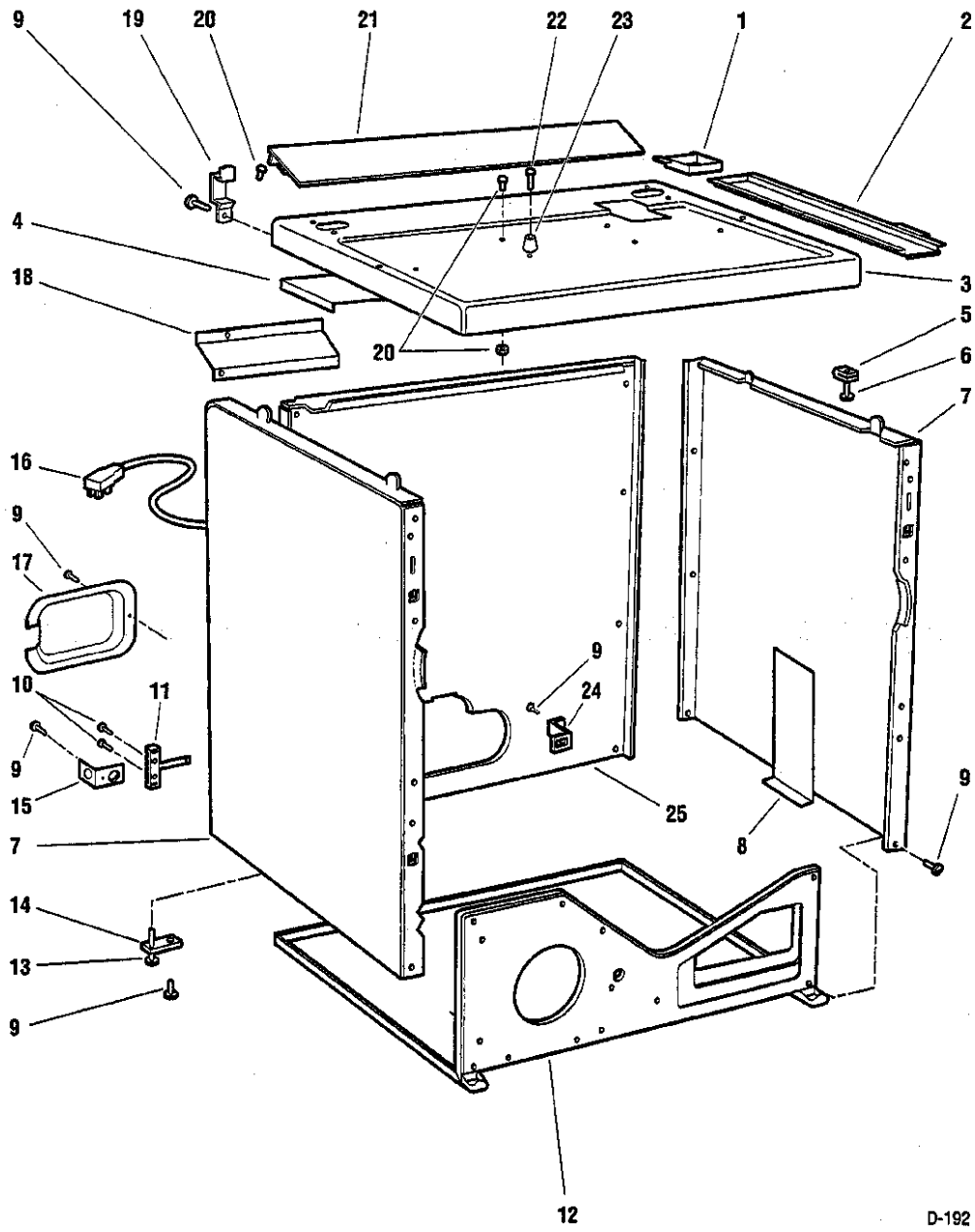

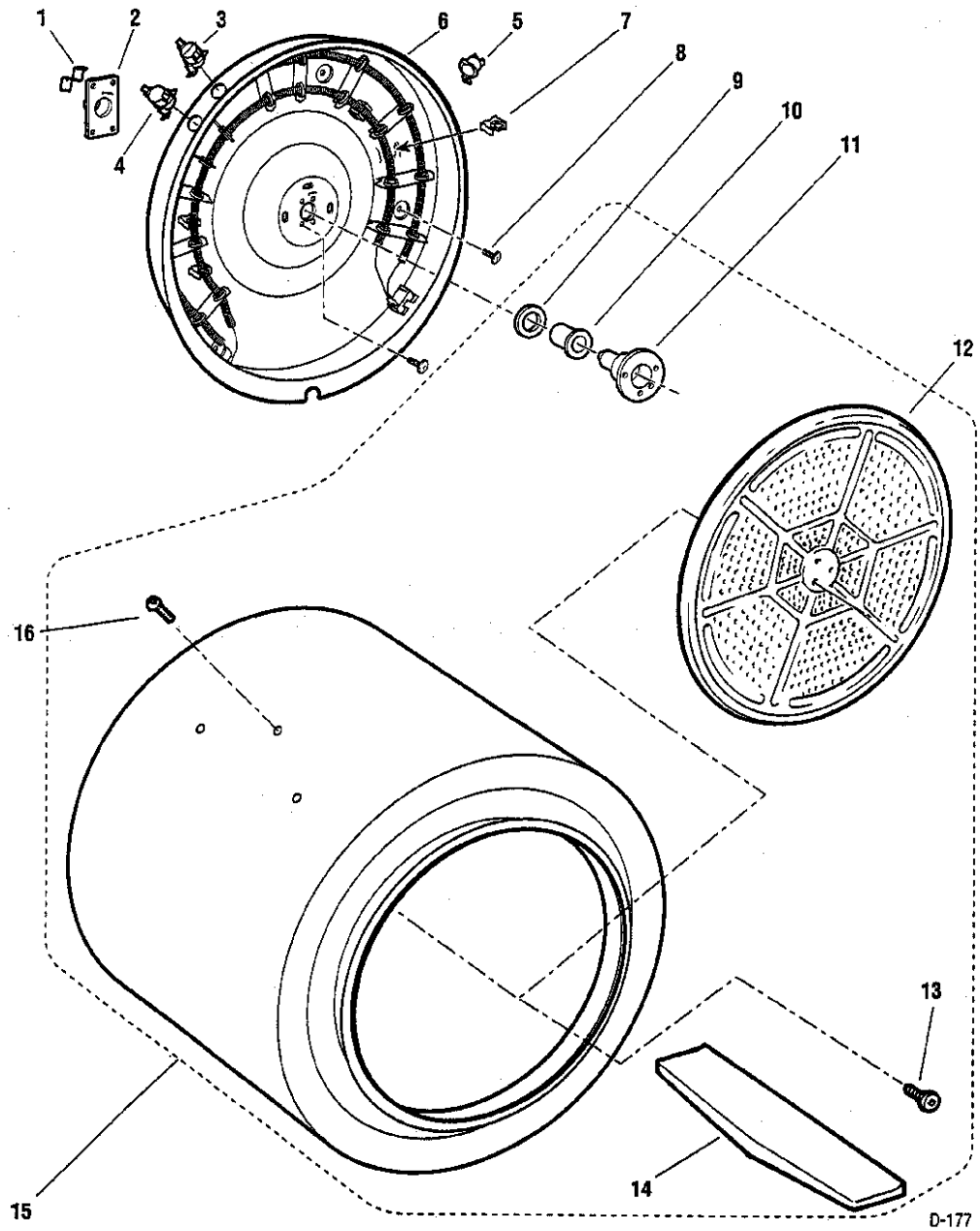

D-177

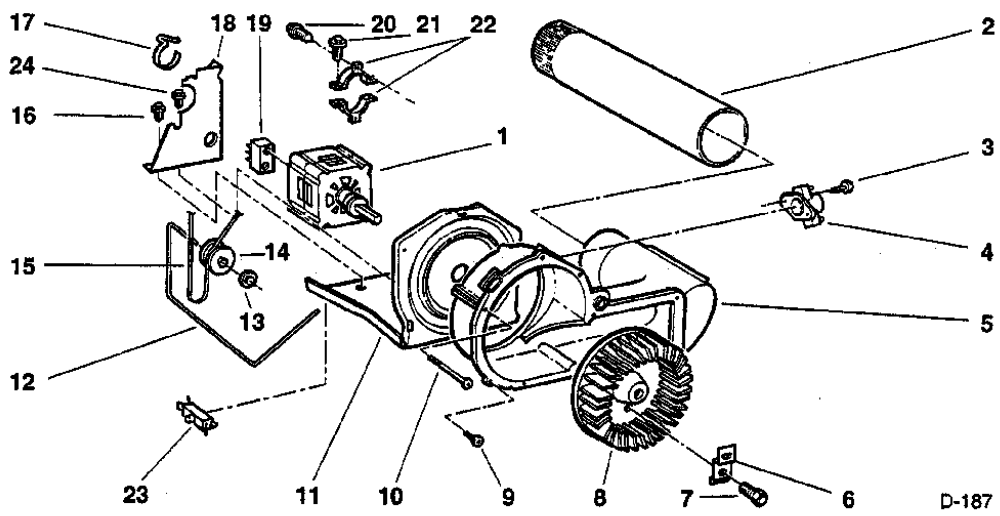

D-187

